

FLS 3D Forward Looking Sonar

ECHAPILOT



INTRO

Daniamant specialises in the development and manufacturing of safety equipment for the commercial and leisure marine industry. Safety at sea is the core mission for Daniamant and it strives to produce and develop products that will save lives at sea. As the world's leading manufacturer of life jacket lights, Daniamant feels an obligation to ensure the safety of all people at sea. Its motto, Safe People, Safe Systems, Safe Sailing, runs deep in the organisation and Daniamant always has its sights on maximising its contribution to the safety of the marine industry, continuously striving to develop its products to exceed the marine safety standards.

The Danish-based marine electronics company acquired 100% of the UK based company EchoPilot who specialised in the design, development, and manufacturing of advanced Forward Looking Sonars in September 2017. Forward Looking Sonars are aimed to enhance the vessel's safety in uncharted waters and remote areas by scanning and displaying the seabed in front of the vessel.

The new version of 3D Forward Looking Sonar was released in January 2018 by Daniamant. It is a revolutionary collision avoidance device designed specifically for the leisure and commercial market. It has two different computers that process all the rendering of data. The first has a transducers interface, which in combination with a complicated algorithm, maps out how the sea bed looks. This filtered data is then sent through to a visual processor, which takes the data and puts it into a 3D image. The algorithm itself is so complex but finally, a Bulgarian mathematics professor managed to design an algorithm that works and makes the EchoPilot so unique.

It is a very complex technology however, in simpler terms, the transducers scan in a 60-degree forward view. They send out a ping at a 200khz frequency. When the sound is received back, depending on the time it takes to send the sound back, you can identify its distance. The EchoPilot 3D FLS has a 100m depth range and a forward distance range of 200m. The EchoPilot 3D FLS displays a 3-dimensional representation of the underwater scene ahead of the boat. The seabed terrain and potential hazards are shown, for the first time, with unparalleled realism. The importance of forward-looking sonar technology is the depth to range ratio. EchoPilot has a staggering 20 x depth ratio! This means that you can see 100 meters ahead with only 5 meters of water underneath your boat. This is the highest ratio in Forward Looking Sonar technology!

The Transducers and Skin Fittings

1. Transducer

The FLS 3D system consist of two retractable Transducers which are mounted in the hull via two thru-hull skin fittings.

The transducer consists of a starboard and a port-side transducer. Each transducer scans a 30 degree view of the seabed to create the total 60 degree forward view.



The Transducers work on a 200khz frequency to be able to give them a maximum range of 200 meters ahead and 100 meters depth.

Both Transducers are equipped with a pointer pin for easy installation. The pointer indicates which direction the transducer should be turned. The pointer should point straight ahead toward the vessel's direction.

Both transducers are marked with port-side and starboard-side markers for easy indication of which side of the vessel the transducer is to be installed.

Both Transducer are also equipped with O-Rings for extra seal inside the thru hull skin fitting.

The transducers are offered in two different length to accompany any hull thickness. The transducers are available in 5" and 10".

The transducers are connected to the Transducer Interface, which we will cover later, and is connected with an 8 pin mini-din connector. The different options in cable lengths are: **2 meters, 12 meters and 22 meters.**

2. Skin Fittings

With the two transducers, two Thru Hull Skin Fittings are included in the system. The skin fittings are offered in three different material depending on your hull type: **Bronze, Steel and Aluminum.**

The Thru Hull Skin Fittings are also offered in two different sizes to accommodate any hull thickness. The Thru Hull Skin Fittings are available in 5" and 10".

5" Skin Fitting

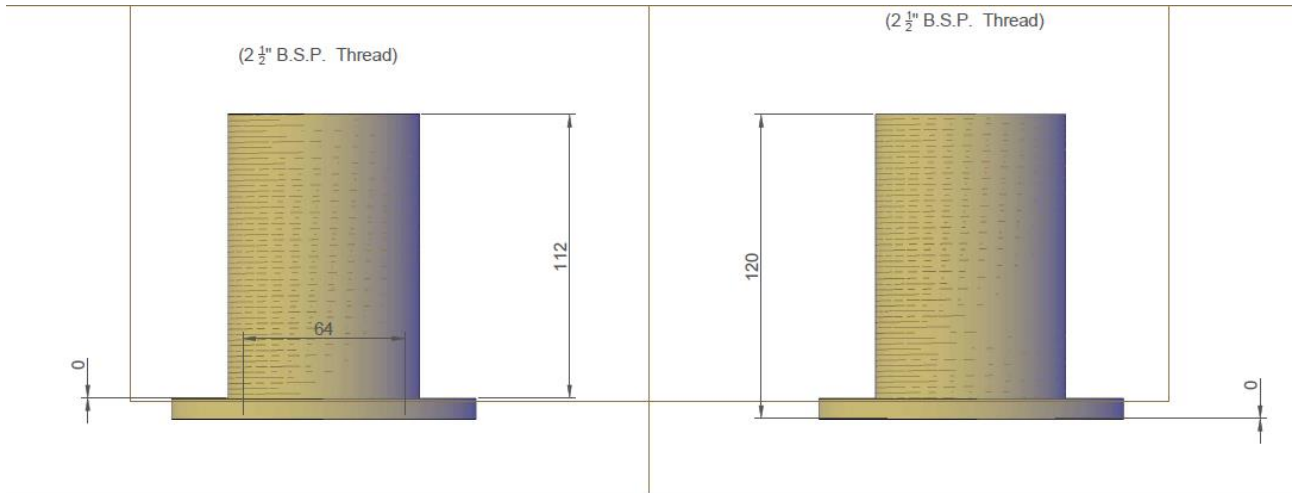

10" Skin Fitting

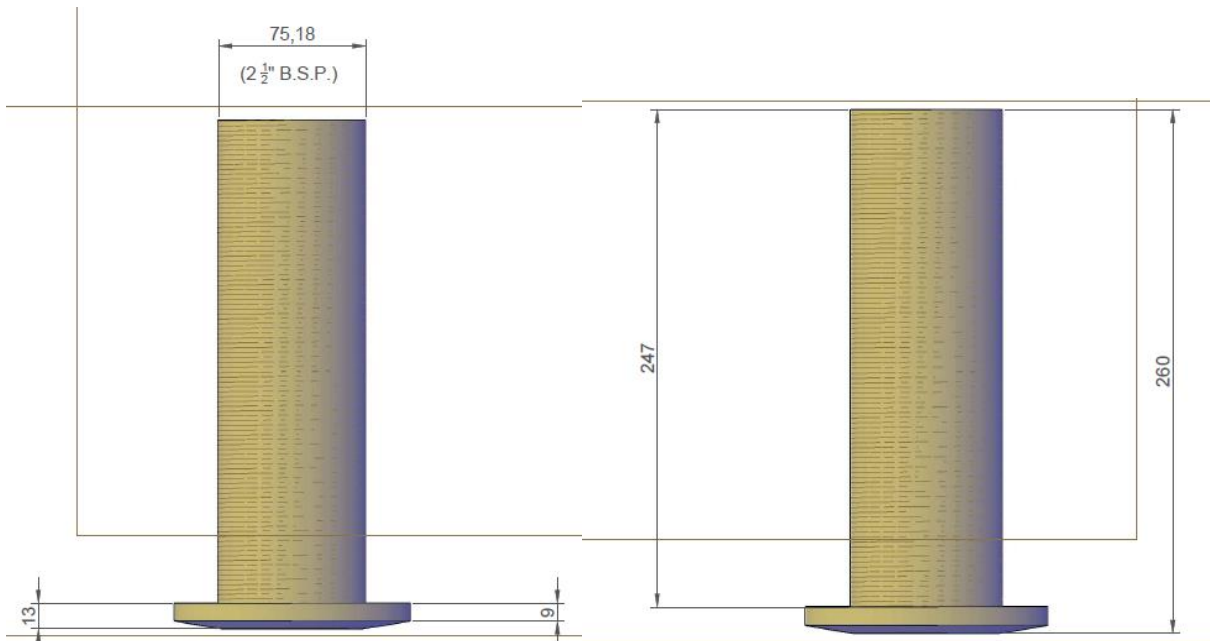

Transducer Interface

The transducer interface is connected to the two transducers. The transducer interface collects all the data from the transducers and renders the data through an algorithm. The data is then sent to the visual processor, which we will get to later.

The transducer interface can be placed up to 22 meters from the two-transducer location.

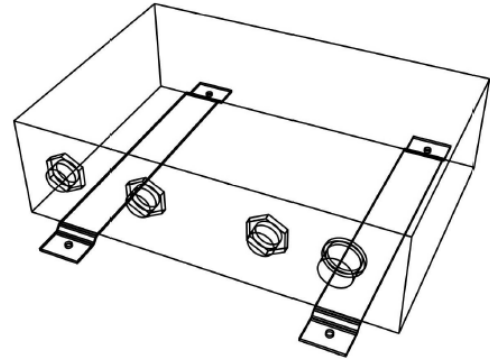
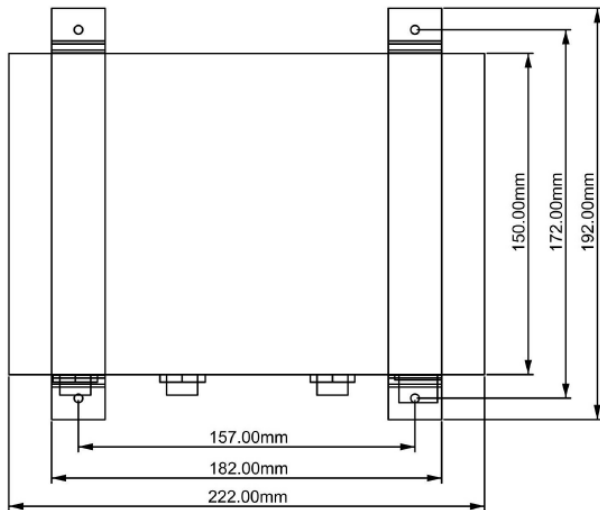

Echopilot FLS 3D Trans. Interface	Versions Nr.: 1
Tegning Nr.: UK10024	Tegner: JC
Daniamant Electronics A/S Industrivej 24C 3550 Slangerup	Størrelsesforhold:
	Vare Nr.: 31429
	Dato: 03/11-2017

Visual Processor

The Visual processor is the computer that renders the data from the Transducer Interface into the 3D image rendered on your display.

The Visual processor is connected to any third-party display or Multi-Function Display with a video input. The Visual Processor has HDMI and VGA video output. If your current display does not have HDMI or VGA video input, then a converter can easily convert the signal to the video signal your display supports. By using a video splitter, you will be able to display the FLS 3D image on multiple displays. This will allow you to have the image displayed on the bridge and in the control room for example.

The Visual Processor is connected to the Transducer Interface. They are connected via a Data Cable, which is available in the following lengths: **10 meters, 20 meters, 30 meters, 40 meters, 50 meters, 60 meters, 70 meters, 80 meters, 90 meters, 100 meters.**

The Visual Processor is powered with 12v or 24v

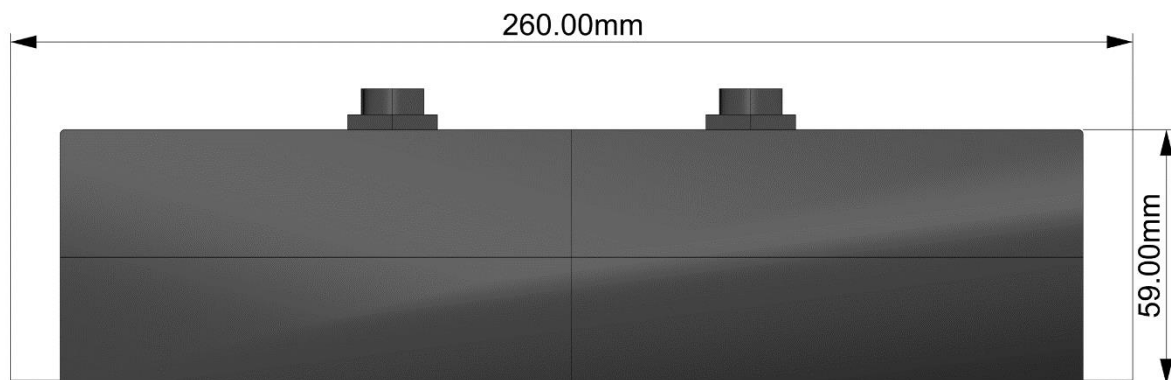

Keypad

The Keypad is used to Power up the FLS 3D system, adjust range settings, change system settings etc.

The Keypad is connected to the visual processor via an 8 pin mini-din connector. The different cable lengths for the keypad are: **2 meters, 12 meters, 22 meters.**

You can have two keypads connected to the visual processor simultaneously. This will allow you to control the FLS 3D system from two different locations on your vessel.

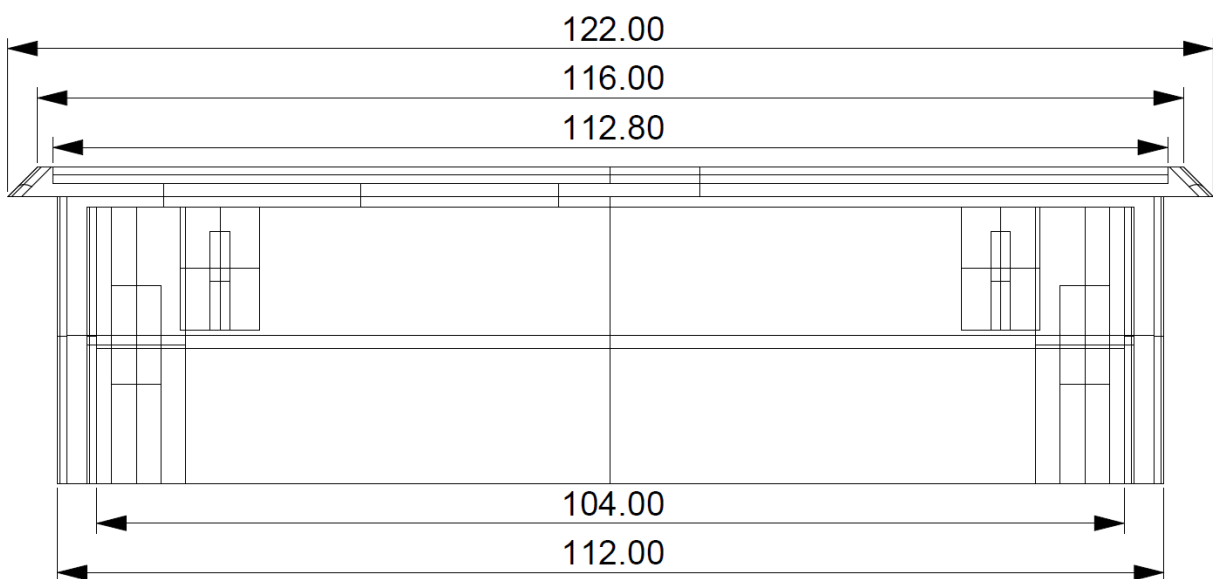

Specs

	EchoPilot FLS 3D
Operational Speed	20-25 knots
3D Forward Looking Display	✓
Bottom Mapping Range	20x water depth
Maximum Depth Detection	100m
Maximum Forward Range	200m
Operating Frequency	200 kHz
Power Requirements	12/24 V, ~20W
Maximum Output Power	28W
Angular Accuracy	~1.5 degree
Roll/Pitch Stabilization	N/A
Operating System	Windows
Update Rate	1 – 1½ second
Video Output	HDMI and VGA
Power Consumption – Standby Mode	400mA
Power Consumption – Active Mode	1200mA