

# Manual for FLS 3D Forward Looking Sonar ECHOPILOT



## **INTRO**

Thank you for purchasing the FLS 3D Forward Looking Sonar.

Your new EchoPilot instrument has been manufactured to the highest standards by the dedicated staff of a company with many years of experience in marine electronics. You have invested in the most up to date technology available and in a product rigorously tested in the laboratory and at sea.

All goods of our manufacture are backed by a 2 year warranty. Expert advice and guidance is always available by Telephone or mail - just ask for customer service.

**Nobody enjoys reading manuals, but please continue to read this one! Installing your instrument correctly is vital to get the maximum performance, pleasure and safety from your equipment, so please take the time to read the instructions.**

### **Please observe the following warnings:**

**Please do not cut the transducer cables** - they are fine multi-core cable matched to the transducer.

**Please do not remove the transducer plug from its cable** - if a hole is too small make the hole bigger! Any join in the cable will reduce sensitivity / performance.

### **Disclaimer:**

**Echopilot makes no warranty as to the accuracy or completeness of data that is included or may be downloaded or used in connection with this product, and EchoPilot disclaims any and all express, implied or statutory warranties including the implied warranty of merchantability and implied warranty of fitness for a particular purpose. It is the user's responsibility to use this product prudently. This product is intended to be used only as a secondary aid to navigation and must not be used for any purpose requiring precise measurement of distance, depth, location, or topography.**

**INDEX**

<b>1. Operating Instructions</b> .....	4
<b>2. Setup Instructions</b> .....	5
<b>3. How FLS Technology Works</b> .....	6
<b>4. Guidance on use</b> .....	7
<b>5. Installation Instructions</b> .....	8
<b>Transducer Installation</b> .....	8
<b>Transducer Interface Installation</b> .....	10
<b>Visual Processor Installation</b> .....	11
<b>Keypad Installation</b> .....	13
<b>Wiring Overview</b> .....	13
<b>6. Technical Specifications</b> .....	14
<b>7. Fault Finding</b> .....	15

## 1. Operating Instructions

### **Operation:**

Your EchoPilot 3D forward sonar is designed to be simple to operate and easy to interpret, though practice always helps with understanding any new instrument on a boat. The 3D looks under the water up to 200 metres ahead of the vessel. The distance ahead that the 3D FLS sees depends on the depth of water below the boat and the laws of physics. The transmit 'ping' radiates at all angles down and out from the vessel, hits the sea bed and some of it is returned to the transducer's receivers.

As the 'ping' travels further away from the boat, it hits the sea bed at an increasingly acute angle. At a certain point the angle will be so acute that the 'ping' is not returned, and the sea bed information is lost - this determines the maximum view ahead, though often 10 to 20 times depth ahead.

In the horizontal plane the 3D covers an area about 30 degrees either side of the centre line of the boat or 60 degrees overall.

Calibration in degrees can be seen on the display. In the vertical plane the 3D can see from under the transducers to the sea surface ahead. The depth colour scale on the right hand side of the screen shows red for the shallowest readings, through the colours of the rainbow up to dark blue for the deepest readings.

All depths shown are the depths below the sea surface. Depth contour lines are shown on the display to assist interpretation.

### **To Switch on:**

To switch on the EchoPilot 3D press the power button. There is a five second delay between pressing the button and the LED on the keypad illuminating. Shortly after the LED is lit the display will show the EchoPilot logo. From this point the system will take approximately 30 seconds to boot.

The system will boot straight into the EchoPilot 3D user interface, set to the 40m range and will start working straight away.

### **To Switch off:**

To switch off the EchoPilot 3D press the power button. The Echopilot logo will appear and a message saying “shutting down” will appear. The shut down takes approximately 10 seconds. Once the system is off the display will become blank and the LED on the keypad will turn off.

It is also possible to execute a forced shut down of the system by pressing and holding the power button for three seconds. This is bad practice and should only be done in emergency situations where sonar blackout is required immediately.

### **To Change Range:**

To change range use the up and down keys on the Keypad. Use the up key to increase the range and the down key to decrease the range. If you press the up or down key several times it will jump instantly to the required range. For example if you are on the 40m range and you press the up key three times the range will jump instantly to the 100m range.

### **Range settings:**

40m, 60m, 80m, 100m, 150m, 200m

## **2. Setup Instructions**

### **Settings Menu:**

In order to access the settings menu press the menu button. The left/right keys move between the settings. The up/down keys change the values of the current setting. The enter key saves the changes to the settings and closes the settings screen.

### **Com Port**

This value should be set to COM 1.

### **Units**

This value can be set to either metres or feet.

### **Bow offset**

This value should be set to the distance that the transducer is set back from the bow.

### **Depth Below Waterline**

This value should be set to depth that the transducer is below the waterline.

### 3. How FLS Technology Works

#### Sonar Beam

The EchoPilot 3D is a unique and patented invention. It can see through a full arc of 90 degrees, from straight ahead to straight down.

The transducer has a horizontal beam of 60 degrees (port to starboard).

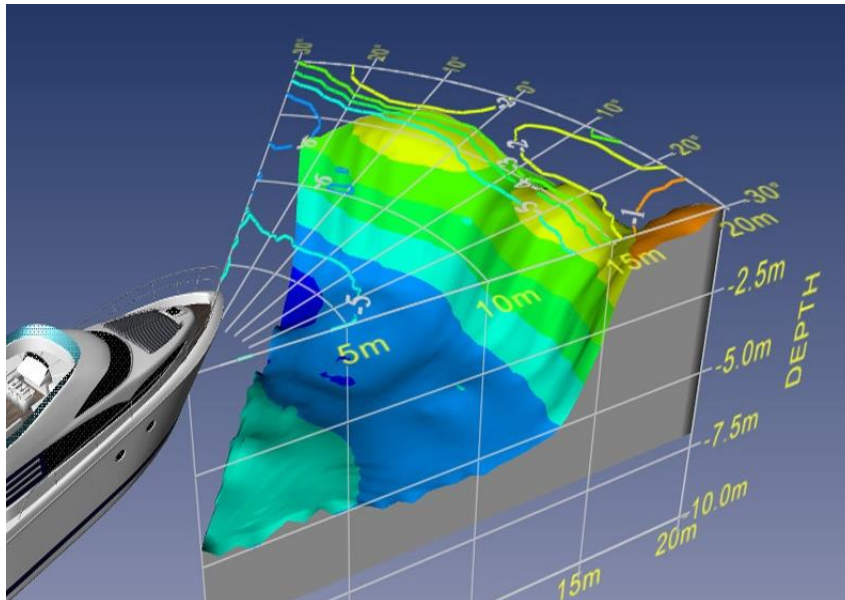

#### Distance Ahead

The distance ahead that the FLS can see depends on the depth of water below the vessel, and the laws of physics. The transmit 'ping' radiates at all angles down and out from the vessel, hits the seabed and some of it is returned to the transducer's receivers.

As the 'ping' travels further away from the boat, it hits the sea bed at an increasingly acute angle. At a certain point the angle will be so acute that the 'ping' is not returned, and the seabed information is lost - this determines the maximum view ahead.

When on a flat muddy bottom (e.g. river or estuary) the FLS will show the seabed up to ten times the depth away from the boat. This ratio increases if the seabed shoals upward. Rocky bottoms are better targets than muddy ones, and hard vertical surfaces like quay walls, rocks or coral reefs will often be seen at considerable distances.

## **4. Guidance on use**

### **Practice**

When learning to interpret the screen practise with clear targets, e.g. a quay wall. Try moving around an obstruction very gently to see what the maximum range is that different targets become visible.

### **!!!! WARNING !!!!**

If approaching a target select a range longer than you think you need. Most people (including us!) seriously underestimate distances to quays, buoys, walls etc.

Note that going astern can push turbulence past the transducer reducing sensitivity or sometimes obliterating all the picture so take care! Manoeuvre with the minimum use of astern (reverse) power, especially with the propeller (on twin screw vessels) on the side of the transducer.

Turbulence from other vessels, especially in shallow water can also adversely affect performance. Algae (normally in spring), Plankton and pollution can all show up as 'noise' on the LCD screen.

### **Operating the FLS 3D at Speed**

Ultrasonic signals travel well through solids and liquids but are greatly attenuated in air. It follows that a stream of turbulence and air bubbles will limit the performance of the FLS system, or any depth system for that matter. However, if a place can be found on the hull where there is a clear flow of water, then good results can be obtained even at speed.

## **5. Installation Instructions**

### **Transducer Installation**

The choice of transducer position will have a major effect on final performance so please consider carefully all factors and if in any doubt, telephone the factory.

The transducers should be mounted vertically, equidistant from the centreline. They must also be the same distance from the bow. Take great care to mount the transducers with the brass arrows on top pointing straight forward in the sailing direction.

Fairings, pads, tapered washers may be required during the fitting of the transducers. Consideration must also be paid to access for maintenance.

Do not fit downstream of any other through hull fittings (for example intakes, log, toilet sea cocks etc) and choose a location with good access for withdrawing the transducer for cleaning.

The transducer should ideally be vertical in the fore and aft plane at running trim. If it leans forward the seabed will appear to slope up, and if it rakes aft then a degree of surface clutter may show.

Sonar cannot see around corners so before installing stand under the boat with your head near the proposed position and check that you can see from your toes up to above the horizontal ahead. If the boat has a full or deep forefoot and is shallow aft a forward mounted transducer maybe necessary.

Each transducer is tuned to work with its own cable, as such the cable must not be cut and the plug must not be removed. If it does not reach then move the location of the transducer interface or contact us.

# **NEVER CUT THE TRANSDUCER CABLE**



## Sailing direction

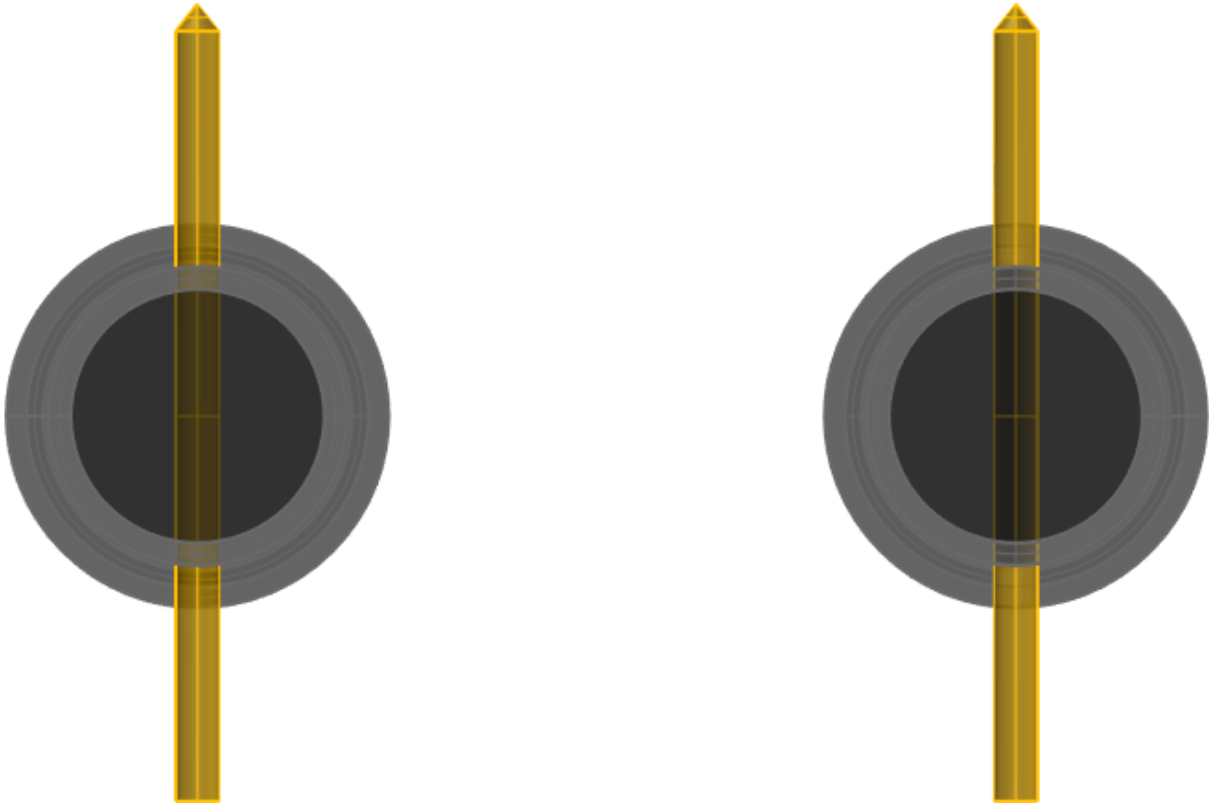

(Top view)

**Note:** Fit port transducer (red bands) to port and starboard transducer (green bands) to starboard

## Transducer Interface Installation

The transducer interface requires reasonable protection from moisture. Ensure that you mount it within reach of the transducer cables and the data cable.

All the plugs on the transducer interface have a threaded locking ring in order to prevent them from coming loose through vibration, and to protect from moisture. Do not over tighten these locking rings.

The transducer plugs are both 8pin mini din plugs. Make sure that the correct transducer is connected to the correct plug. Each transducer is clearly marked with either port or starboard. The transducer interface is also clearly marked showing which socket is for the port transducer and which is for the starboard.

The data cable has a five pin mini din plug, there is only one socket on the transducer interface that this will plug into, which is clearly marked data.

The power cable plugs into the socket that is marked power. The power cable has two cores, red ( positive +12 / 24v), and black ( negative 0v).

The transducer interface will require four mounting screws or bolts which will go through the stainless steel mounting brackets. We advise the use of stainless steel fixings.

Do under no circumstances unscrew the two mounting brackets !

As shown on the diagram below the spacing for the fixings is 157 mm x 172mm.

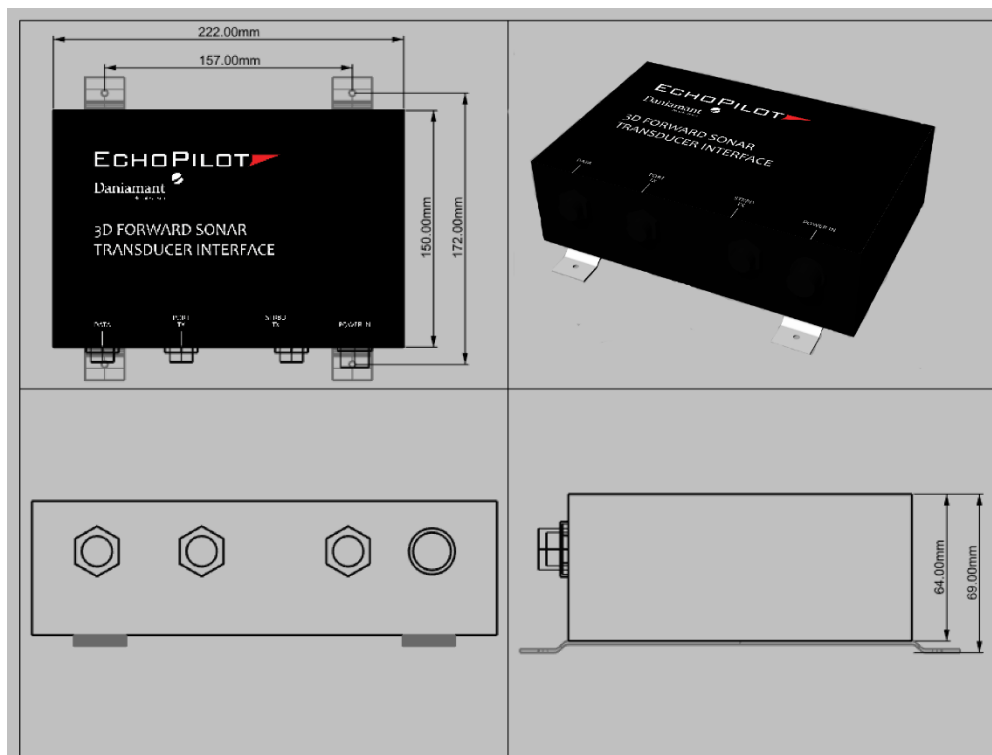

## Visual Processor Installation

The visual processor is based on a pc. As such it should be mounted in a protected location. However it should still be accessible so that upgrades can be made, by means of inserting a usb dongle.

The data cable from the transducer interface (5 pin mini din plug) plugs into the socket that is marked data. The plug has a threaded locking ring in order to prevent it from coming loose through vibration, and to protect from moisture. Do not over tighten this locking ring.

The power cable plugs into the large rectangular socket on the rear of the case. The power cable has three wires. Red connects to positive (+12 / 24v). White connects to positive (+12 / 24v). Black connects to negative (0v).

If the visual processor is connected to a 12v supply then the transducer interface must also be connected to a 12v supply. The positive of both the transducer interface and the visual processor must be at the same potential with respect to ground.

If the visual processor is connected to a 24v supply then the transducer interface must also be connected to a 24v supply. The positive of both the transducer interface and the visual processor must be at the same potential with respect to ground.

The grounds (0v connection) for both the transducer interface and the visual processor must be at the same potential.

The keypad cable (8pin mini din) connects to the socket marked keypad on the visual processor. The plug has a threaded locking ring in order to prevent it from coming loose through vibration, and to protect from moisture. Do not over tighten this locking ring.

The visual processor has two display output options. These are HDMI and VGA. The HDMI and the VGA outputs will provide high quality pictures and are the advisable outputs to use.

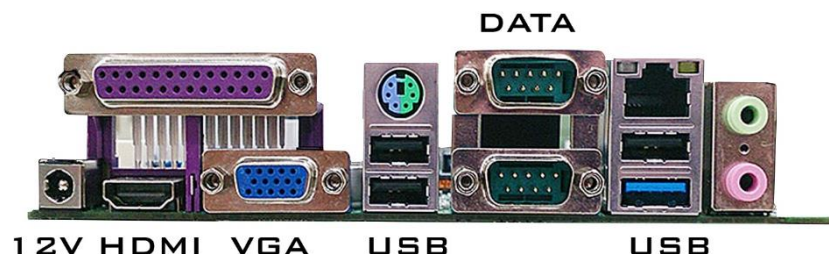

The visual processor will require four mounting screws or bolts which will go through the mounting brackets. We advise the use of stainless steel fixings.

As shown on the diagram below the spacing for the fixings is 212 mm x 128mm.

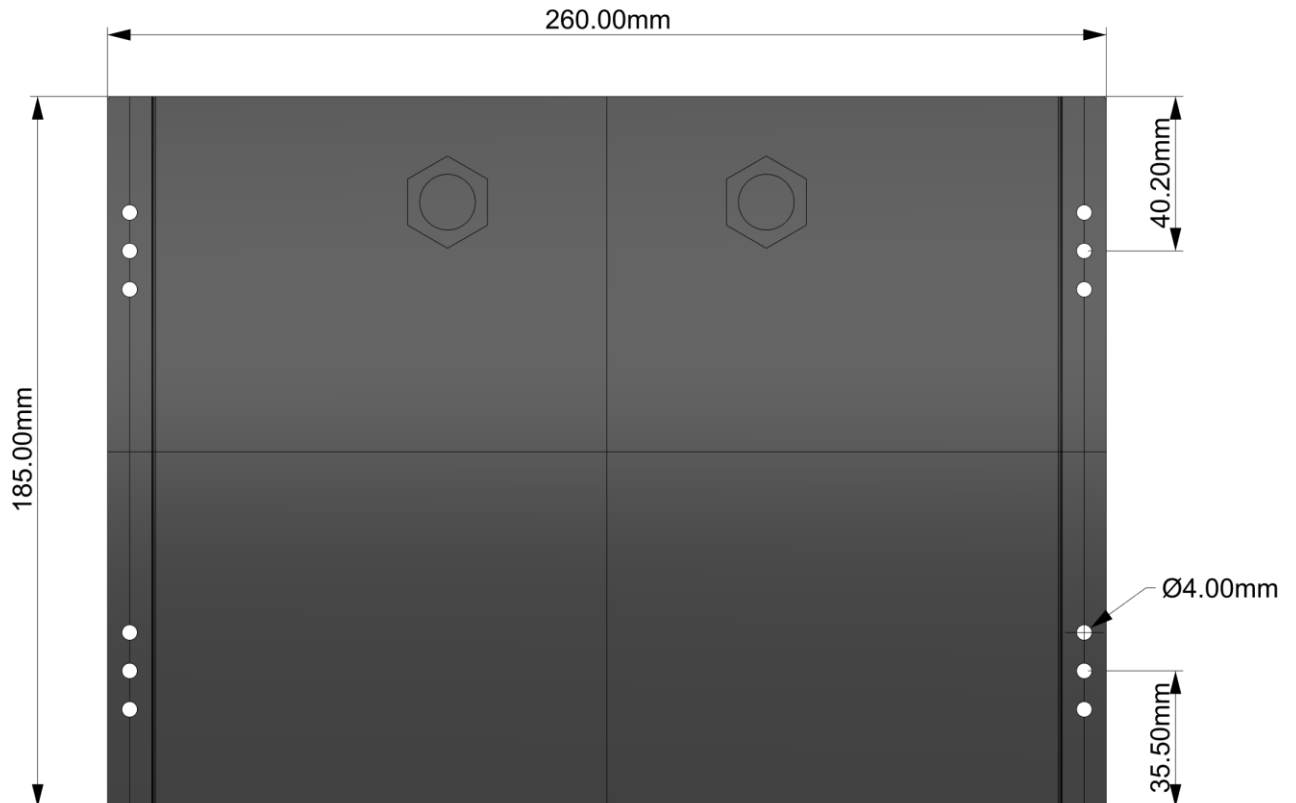

## Keypad Installation

The waterproof keypad plugs into the visual processor as explained on the previous page.

The keypad should be mounted as near as possible to the display which the EchoPilot 3D is being shown.

The keypad has been designed for panel mounting. It is provided with a stainless steel mounting bracket, two plastic m6 studs and two m6 plastic nuts.

Once you have decided on the best position for the keypad (making sure that the cable reaches the visual processor), cut out a rectangular hole measuring 103mm x 161mm. Place the keypad into the cut out with the m6 studs already screwed into the threaded holes in the back of the keypad (you may also wish to seal with a small amount of suitable sealant). Place the stainless steel bracket on the studs and tighten with the plastic nuts. Do not over tighten the mounting nuts.

## Wiring Overview

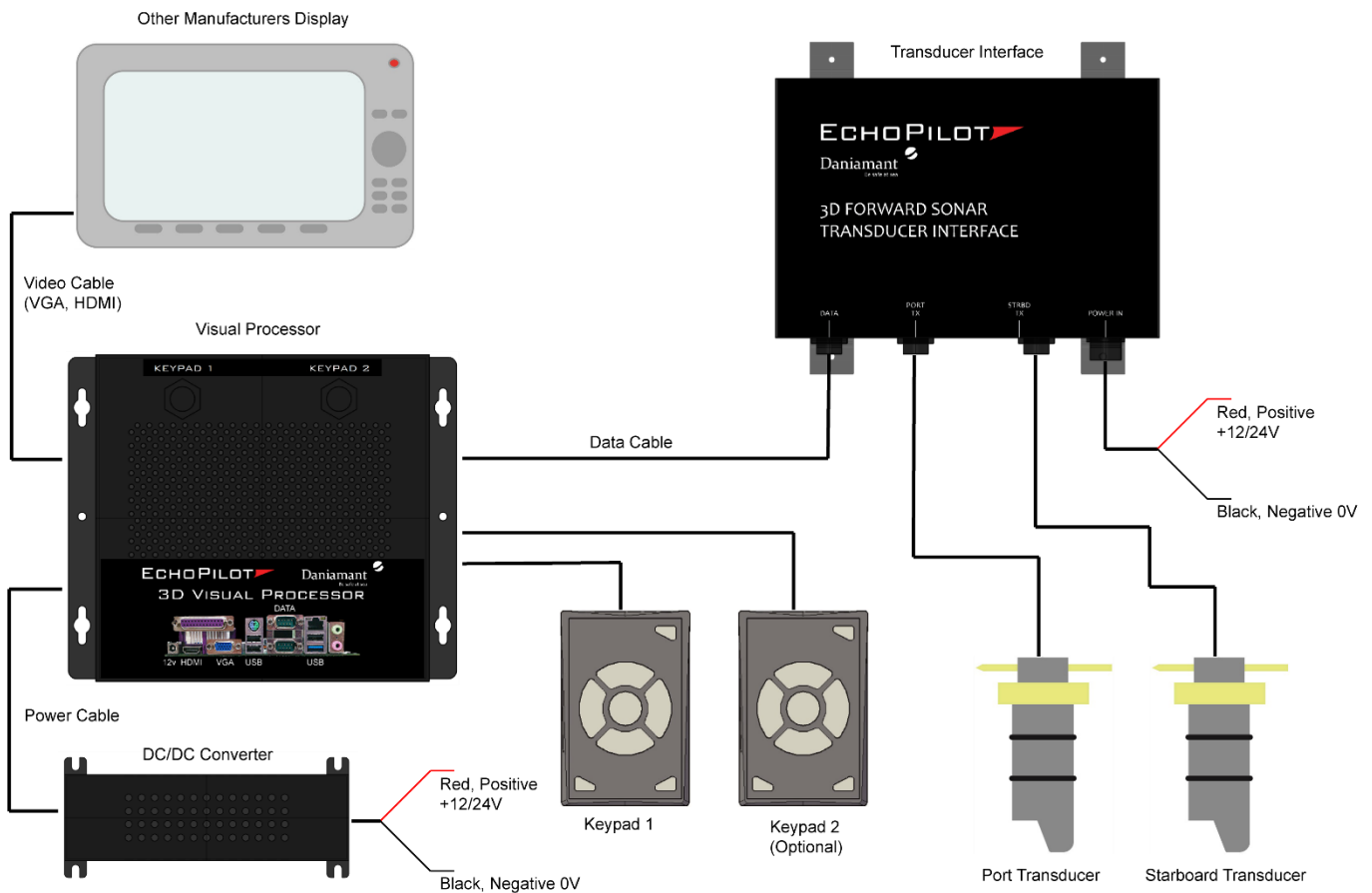

## 6. Technical Specifications

Specification	EchoPilot FLS 3D
Operational Speed	20-25 knots
3D Forward Looking Image	✓
Display	3rd part dependent
Bottom Mapping Range	20x water depth
Display Update Rate	1 second pr. update
Maximum Depth Detection	100m
Maximum Forward Range	200m
Operating Frequency	200 kHz
Power Requirements	12/24 V, ~20W
Maximum Output Power	28W
Angular Accuracy	~1.5 degree
Roll/Pitch Stabilization	N/A
Operating System	Windows
Update Rate	1 – 1½ second
Video Output	HDMI and VGA
Built-in Test Facility	Yes
Multi Display Option	Yes

## **7. Fault Finding**

### **Some Common Faults**

#### **Display doesn't switch on (no display):**

- Battery not connected
- Battery voltage too low

#### **My 3D has no coms. (red cross):**

- Check that the coms port is set to com1 (within menu)
- Check power to the transducer interface
- Check com cable

#### **Poor seabed picture or excessive noise:**

- Suitable range not selected (try to fill screen with seabed)
- Poor connection of transducer
- Battery voltage low - use Test Mode to check Tx voltage
- Transducer mounted at an angle
- Turbulence at transducer location
- Interference from other 200KHz sounders (same boat or other boats)
- Turbulence/wake from other boats
- Polluted water or Plankton bloom (usually early summer)
- Dirty transducer/covered with barnacles
- Choppy sea state - can cause surface noise

**The display seems to be unstable or jumpy:**

- The FLS 3D is a "Real Time Sonar" not a historical recording like a fish finder, so some pings will come back and some will miss. It updates about once a second and two successive pictures will rarely be exactly the same. This can give an uneasy picture.
- We recommend, to test out in open water with the boat moving gently through the water.
- Please check the videos on the website for reference



# ECHOPILOT

Information in this document is subject to change without notice. No part of this document may be reproduced or transmitted in any form or by any means, electronic or mechanical, for any purpose, without the express written permission of Daniamant Electronics A/S.

Copyright © 2017 by Daniamant Eletronics A/S. All rights reserved.

**Protected by USA Patent 5530680 and European (UK) Patent 0624253**

Author: Chris Phillips

Last Updated: 06.10.2017 (Johnny Christensen)

For up to date information and advice, please telephone, browse our Website, or send us an E-Mail:

**e-mail: [info@echopilot.com](mailto:info@echopilot.com)**

**website: [www.echopilot.com](http://www.echopilot.com)**