

SAFE SAILING

FORWARD LOOKING SONAR

FLS 3D - 30 Degree TECHNICAL DATA SHEET

SPECIFICATIONS

Operational Speed	• Up to 10 Knots
3D Forward Looking Image	• Yes
Display	• 3rd part dependent
Bottom Mapping Range	• 20x water depth
Display Update Rate	• 1 second pr. update
Maximum Depth Detection	• 100m
Maximum Forward Range	• 200m
Operating Frequency	• 200 kHz
Power Requirements	• 12/24 V, ~20W
Maximum Output Power	• 28W
Angular Accuracy	• ~1.5 degree
Roll/Pitch Stabilization	• N/A
Operating System	• Windows
Update Rate	• 1 – 1½ second
Video Output	• HDMI and VGA
Multi Display Option	• Yes
Integrates Directly With	• Raymarine, Simrad, B&G and Lowrance

Standard Kit FLS 3D-30 Degree Gen4 For Raymarine Integration

- 1 x FLS 3D 5" Transducer
- 1 x 5" Bronze Thru Hull Skin Fitting
- 1 x Transducer Extension Cable
- 1 x FLS 3D Transducer Interface Box
- 1 x FLS 3D Data Cable
- 1 x FLS 3D Visual Processor
- 1 x On/Off Switch
- Power cables

Standard Kit FLS 3D-30 Degree For 3rd Party Display

- 1 x FLS 3D 5" Transducer
- 1 x 5" Bronze Thru Hull Skin Fitting
- 1 x Transducer Extension Cable
- 1 x FLS 3D Transducer Interface Box
- 1 x FLS 3D Data Cable
- 1 x FLS 3D Visual Processor
- 1 x FLS 3D Keypad
- Power cables



SAFE SAILING

FORWARD LOOKING SONAR

FLS 3D - 30 Degree TECHNICAL DATA SHEET

FLS 3D-30 Degree Visual Processor

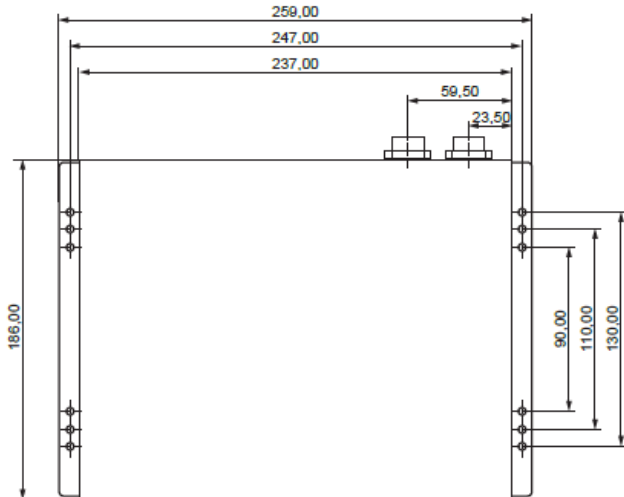

FLS 3D - 30 Degree Transducer Interface Box

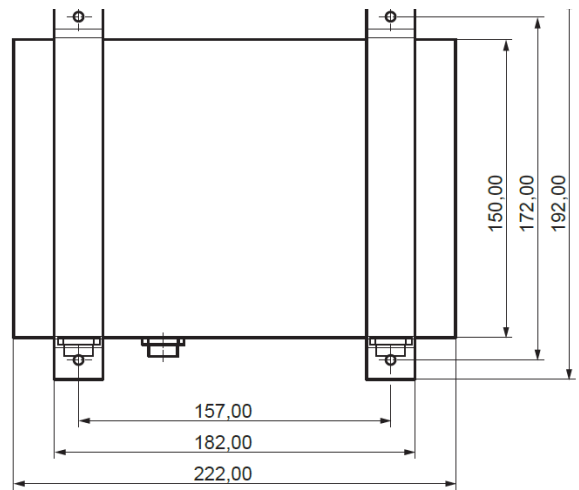

5" Bronze THru Hull SkinFitting

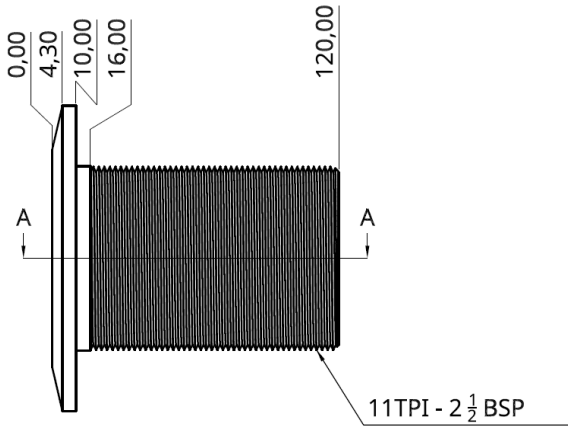

Transducer Inside Skin Fitting

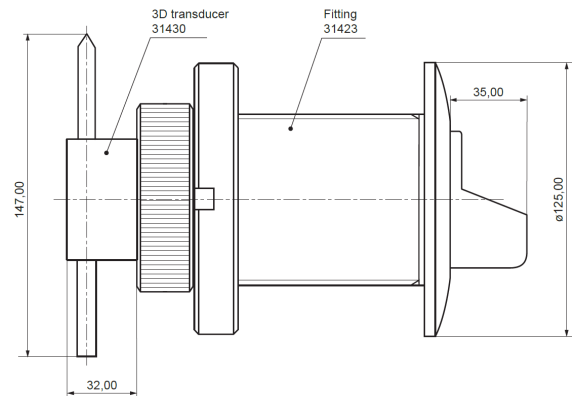

FLS 3D-30 Degree Keypad

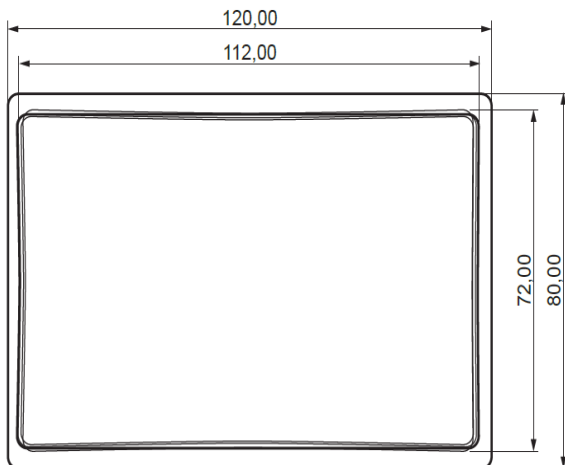

FLS 3D-30 Degree On/Off Button

